



SUBJECT and GRADE	Physical Sciences Gr 12
TERM 3	Week 1
TOPIC	Electric Circuits
AIMS OF LESSONS	<p>Ohm's Law</p> <p>To:</p> <ul style="list-style-type: none">• State Ohm's law in words: The potential difference across a conductor is directly proportional to the current in the conductor at constant temperature.• Determine the relationship between current, potential difference and resistance at constant temperature using a simple circuit.• State the difference between ohmic conductors and non-ohmic conductors and give an example of each.• Solve problems using $V = IR$ for series and parallel circuits (maximum four resistors). <p>Power, energy</p> <p>To</p> <ul style="list-style-type: none">• Define power as the rate at which work is done.• Solve problems using $P = W / \Delta t$.• Solve problems using $P = VI$, $P = I^2 R$ or $P = V^2/R$.• Solve circuit problems involving the concepts of power and electrical energy.• Deduce that the kilowatt hour (kWh) refers to the use of 1 kilowatt of electricity for 1 hour.• Calculate the cost of electricity usage given the power specifications of the appliances used, the duration and the cost of 1 kWh.

	<p>Internal resistance, series and parallel network</p> <p>To</p> <ul style="list-style-type: none"> • Solve problems involving current, voltage and resistance for circuits containing arrangements of resistors in series and in parallel (maximum four resistors). • Explain the term internal resistance. • Solve circuit problems using $\varepsilon = V_{\text{load}} + V_{\text{int resistance}}$ or $\varepsilon = IR_{\text{ext}} + Ir$. <p>Solve problems, with internal resistance, for circuits containing arrangements of resistors in series and in parallel (maximum four resistors).</p>	
RESOURCES	<p>Paper based resources</p> <p>Please refer to the:</p> <ul style="list-style-type: none"> • <i>Electric Circuits topic in the textbook or study guides that learners will have on hand.</i> • <i>Examination Guideline (page 12)</i> • <i>Mind the Gap books (pages 103 - 115)</i> • <i>Past NSC Examination papers (refer to P1)</i> 	<p>Digital resources</p> <p>Refer to the relevant digital resources:</p> <ul style="list-style-type: none"> • <i>WCED ePortal</i> • <i>HeyScience App for Physical Sciences</i> • <i>Past NSC Examination papers</i> • <i>You Tube videos</i> <p>Basic of electric circuits https://youtu.be/m4jzggZu-4s?t=141</p> <p>Ohm's Law experiment https://youtu.be/48_CqnhRbww</p> <p>Internal resistance experiment https://youtu.be/7b1j7j_P84M</p>

INTRODUCTION

Part 1

1. You should be able to define the following terms: Potential Difference, Current Strength, Resistance
2. You should be able to state Ohm's Law, in words.
3. You should be able to do calculations from electric circuits (excluding internal resistance) – calculating current strength, potential difference or resistance of resistor(s) in series and/or parallel circuits.
4. Observe the following two youtube videos:

Basic of electric circuits <https://youtu.be/m4jzgaZu-4s?t=141>

Ohm's Law experiment https://youtu.be/48_CqnhRbww

5. You may now attempt the following questions:

QUESTION 1

- 1.1 State Ohm's law in words (2)
- 1.2 When the total voltage in a circuit is increased, what happens to the total current? (1)
- 1.3 Show the relationship between voltage and current by means of a graph to explain your answer in QUESTION 1.2. (2)
- 1.4 Four identical resistors are connected as shown in the following circuit diagram.

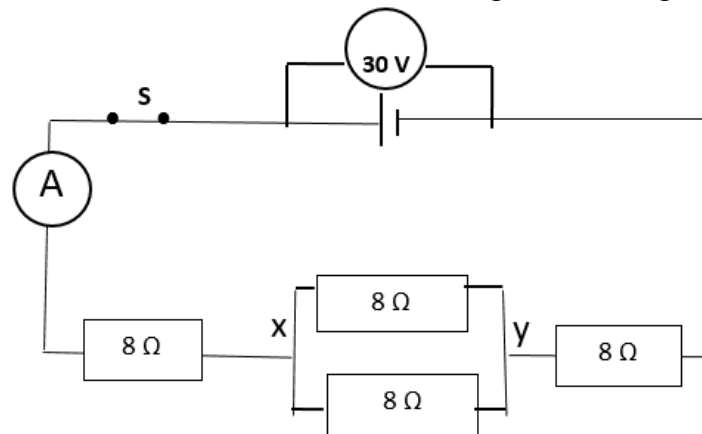

- 1.4.1 What would the reading on the voltmeter be while the switch, S, is open? (1)
The switch, S, is now closed:
- 1.4.2 Calculate the effective resistance of the parallel combination of resistors. (3)

	<p>1.4.3 Calculate the total resistance of the electric circuit. (2)</p> <p>1.4.4 Determine the reading of ammeter A. (3)</p> <p>1.4.5 Hence determine the potential difference across points X and Y. (3)</p> <p>1.4.6 Calculate the amount of charge (Q) that passes point X in the circuit in 2 minutes. (3)</p> <p>1.4.7 One of the 8 ohm resistors in the parallel combination breaks. What will happen to the ammeter reading? Explain your answer. (3)</p> <p style="text-align: right;">[23]</p> <p>QUESTION 2</p> <p>In an electric circuit, 2 resistors of 3Ω and 4Ω are connected in series to each other while 2 other resistors of 4Ω and 6Ω are connected in parallel to each other. Three voltmeters are connected in the circuit, the first over a 9V battery, the second over the 3Ω resistor and the third over the parallel combination of resistors. The circuit also has two ammeters. The first one, A_1, next to the 3Ω resistor and the second one, A_2 in the parallel combination next to the 6Ω resistor.</p> <p>2.1 Draw a fully labeled circuit diagram showing all these components. (5)</p> <p>2.2 Calculate the total resistance of the circuit. (6)</p> <p>2.3 Calculate the reading on A_1 and A_2. (4)</p> <p style="text-align: right;">[15]</p>		
<p>CONCEPTS AND SKILLS</p>	<table border="1" style="width: 100%; border-collapse: collapse;"> <tr> <td style="width: 50%; vertical-align: top;"> <p>Part 2</p> <ul style="list-style-type: none"> • Explain the concept “internal resistance” of a cell/battery MTG p. 106 It is the small amount of energy used up inside a cell/battery. The voltage used up inside the cell is called “lost volts” • Explain what is meant by “emf” of a cell as “the total electrical potential difference across the terminals of a cell when no current passes through the cell or circuit” • Sketch how internal resistance is indicated in a circuit diagram. </td> <td style="width: 50%; vertical-align: top;"> <p>CAN YOU?</p> <ul style="list-style-type: none"> • Explain internal resistance of a battery. • Explain “emf” • Define “potential difference”, “current strength” • State “Ohm’s law” in words. • Draw the graph of V vs I for an ohmic conductor and explain what the gradient of the graph represents. • Draw a graph of V vs I to determine the internal resistance of a battery and explain what does the gradient of the graph represents. </td> </tr> </table>	<p>Part 2</p> <ul style="list-style-type: none"> • Explain the concept “internal resistance” of a cell/battery MTG p. 106 It is the small amount of energy used up inside a cell/battery. The voltage used up inside the cell is called “lost volts” • Explain what is meant by “emf” of a cell as “the total electrical potential difference across the terminals of a cell when no current passes through the cell or circuit” • Sketch how internal resistance is indicated in a circuit diagram. 	<p>CAN YOU?</p> <ul style="list-style-type: none"> • Explain internal resistance of a battery. • Explain “emf” • Define “potential difference”, “current strength” • State “Ohm’s law” in words. • Draw the graph of V vs I for an ohmic conductor and explain what the gradient of the graph represents. • Draw a graph of V vs I to determine the internal resistance of a battery and explain what does the gradient of the graph represents.
<p>Part 2</p> <ul style="list-style-type: none"> • Explain the concept “internal resistance” of a cell/battery MTG p. 106 It is the small amount of energy used up inside a cell/battery. The voltage used up inside the cell is called “lost volts” • Explain what is meant by “emf” of a cell as “the total electrical potential difference across the terminals of a cell when no current passes through the cell or circuit” • Sketch how internal resistance is indicated in a circuit diagram. 	<p>CAN YOU?</p> <ul style="list-style-type: none"> • Explain internal resistance of a battery. • Explain “emf” • Define “potential difference”, “current strength” • State “Ohm’s law” in words. • Draw the graph of V vs I for an ohmic conductor and explain what the gradient of the graph represents. • Draw a graph of V vs I to determine the internal resistance of a battery and explain what does the gradient of the graph represents. 		

	<ul style="list-style-type: none"> Observe the following youtube video on experiment to calculate the internal resistance of a power supply: https://youtu.be/7b1j7j_P84M 	
--	--	--

ACTIVITIES/ ASSESSMENT	<p>Part 3</p> <ul style="list-style-type: none"> Go through the Examples of calculations from electric circuit from Mind the Gap pages 109 – 115. Then work through the exercises under the Consolidation Heading 	
---------------------------	--	--

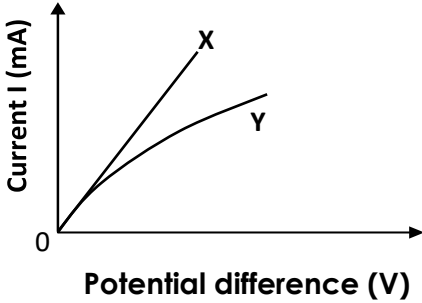
CONSOLIDATION	<p>Now try the following questions as consolidation.</p> <p>QUESTION 1</p> <p>1.1 The two graphs below show the relationship between current and potential difference for two different conductors, X and Y.</p> <p>Graphs of I versus V for two different conductors, X and Y</p>  <p>1.1.1 State Ohm's law in words. (2)</p> <p>1.1.2 Which ONE of the two conductors, X or Y, is ohmic? Refer to the graph and give a reason for the answer. (2)</p>	
---------------	---	--

- 1.2 In the diagram below, a battery with an emf of 6 V and an internal resistance of $2\ \Omega$, is connected to three resistors **P**, **Q** and **R**. A voltmeter **V** is connected across the battery. The ammeter **A** has a negligible resistance.

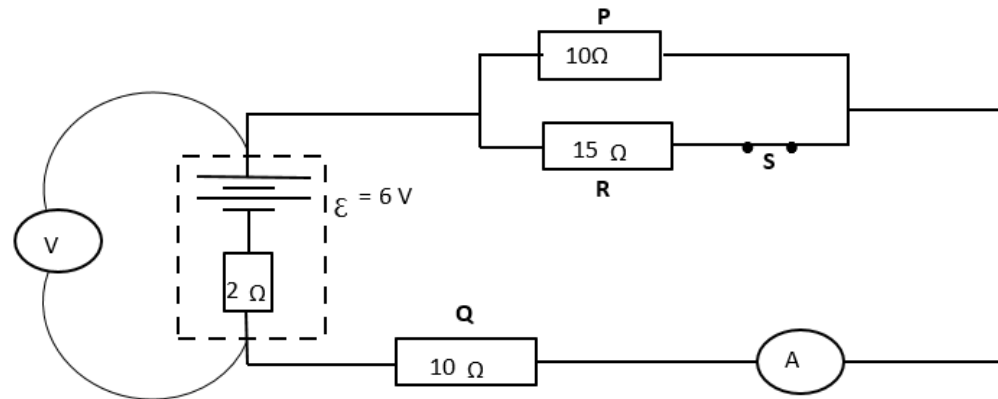

- 1.2.1 Calculate the ammeter reading when switch **S** is closed. (5)

The switch **S** is now open.

- 1.2.2 Will the ammeter reading in QUESTION 1.2.1 INCREASE, DECREASE or REMAIN THE SAME?
Give a reason for the answer. (2)
- 1.2.3 How will the voltmeter reading now compare with the voltmeter reading when the switch is closed? Choose from INCREASE, DECREASE or REMAIN THE SAME. (1)
- 1.2.4 Explain the answer to QUESTION 1.2.3. (3)
- [15]**

QUESTION 2.

2.1 In Circuit 1 below three identical light bulbs, **P**, **Q** and **R**, with the same resistance, are connected to a battery with emf ϵ and negligible internal resistance.

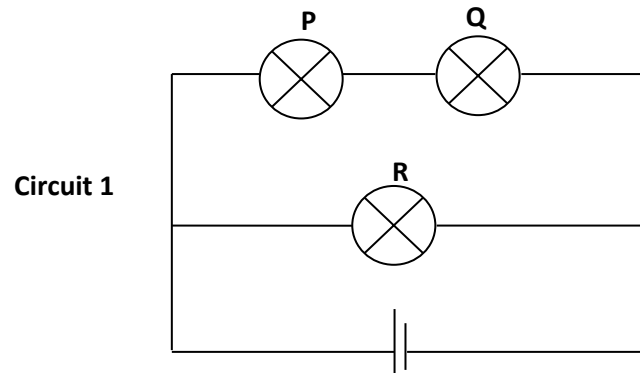

2.1.1 How does the brightness of bulb **P** compare with that of bulb **Q**?
Give a reason for the answer. (2)

2.1.2 How does the brightness of bulb **P** compare with that of bulb **R**?
Give a reason for the answer. (2)

A fourth, identical bulb **T**, with the same resistance as the other three, is connected to the circuit by means of an ordinary wire of negligible resistance, as shown in Circuit 2 below.

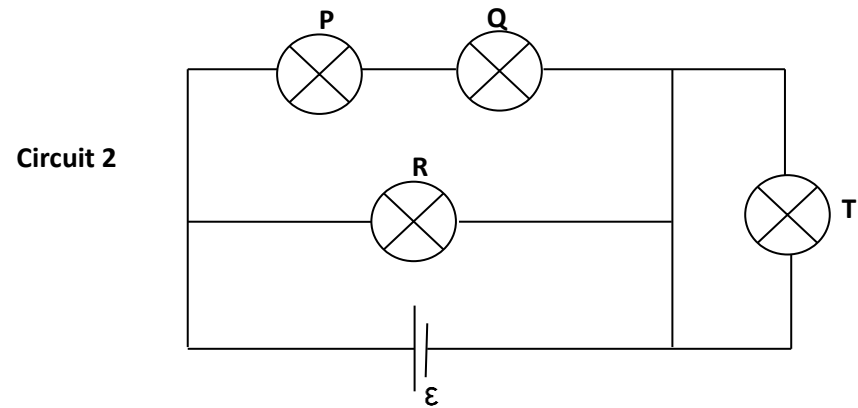

2.1.3 How does the brightness of bulb **T** compare with that of bulb **R**?
Give a reason for the answer.

(2)

2.2 A battery with an emf of 20 V and an internal resistance of 1Ω is connected to three resistors, as shown in the circuit below.

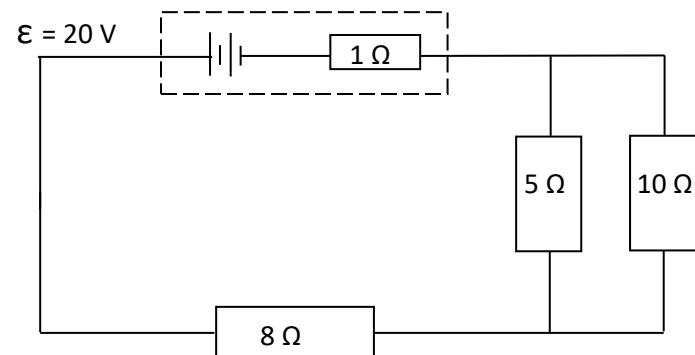

Calculate the:

2.2.1 Current in the $8\ \Omega$ resistor (6)

2.2.2 Potential difference across the $5\ \Omega$ resistor (4)

2.2.3 Total power supplied by the battery (3)

[19]

Memo

1.1.1 The potential difference across a conductor is directly proportional to the current in the conductor at constant temperature. ✓✓

OR The current in a conductor is directly proportional to the potential difference across the conductor at constant temperature. ✓✓ (2)

1.1.2 Graph X. ✓

Graph X is a straight line (passing through the origin) therefore potential difference is directly proportional to current. ✓ (2)

1.2.1

$$R // = 6\ \Omega$$

$$I = 0,33\ \text{A} \quad (5)$$

1.2.2 Decrease. ✓

The total resistance of the circuit increases ✓. (2)

1.2.3 Increase ✓

(1)

1.2.4 The total resistance in the external circuit increases. ✓

Current decreases ✓

"Lost" volts decreases ✓

OR

The total resistance in the external circuit increases. ✓

$V \propto R$ ✓ for constant I ✓

Therefore, V increases.

(3)

[15]

	<p>2.1.1 <u>P and Q burn with the same brightness</u> ✓ same potential difference/same current ✓ (2)</p> <p>2.1.2 <u>P is dimmer (less bright) than R</u> <u>OR</u> <u>R is brighter than P</u> ✓ <u>R is connected across the battery alone therefore the voltage (terminal pd) is the same as the emf source</u> (energy delivered by the source). ✓ OR/OF The potential difference across R is twice (larger/greater than) that of P./The current through R is twice (larger/greater than) that of P. (2)</p> <p>2.1.3 T does not light up at all ✓ Reason The wire acts as a short circuit. ✓ OR The potential difference across T / current in T is zero. ✓ (2)</p> <p>2.2.1 $R_P = 3,33\Omega$ $I_8 = 1,62\text{ A}$ (6)</p> <p>2.2.2 $V_5 = V_{//} = 5,41\text{ V}$ (4)</p> <p>2.2.3 $P = 32,36\text{ W}$ (3)</p> <p style="text-align: right;">[19]</p>
VALUES	<p>In the use of multiplugs: multiplugs are connected in parallel. As more and more appliances are connected to it, the resistance of that circuit in your house decreases, and therefore the current drawn increases. This results in (1) the temperature of the conducting wire increasing and could burn and cause a fire (2) as more current is drawn, the electricity bill increases. Therefore, it is important not to have too many appliances connected to one plug point.</p>